

TORNADO

By Duraquip

2 COMPARTMENT A-TRAILER SPECIFICATIONS

GA DRAWING / HOPPER SPLITS

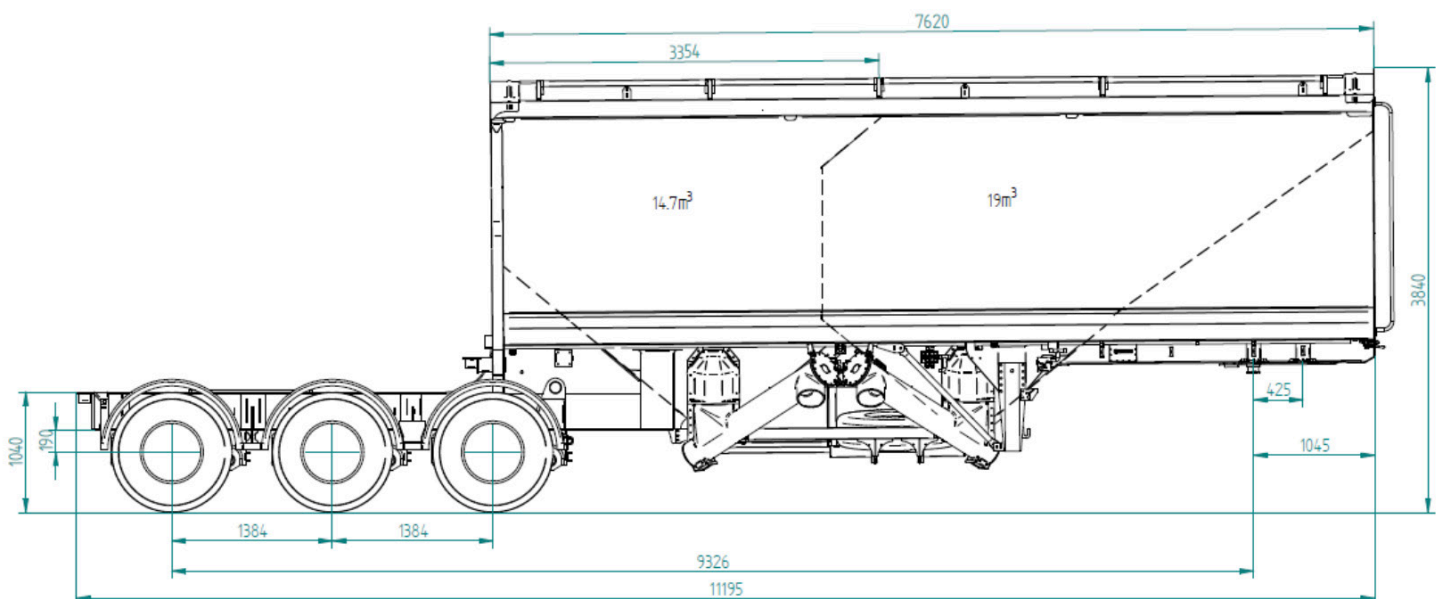

HOPPER CAPACITIES

SUB-FRAME COLOURS



TOTAL	33.7M3	WHEAT	BARLEY	FERTILISER	UREA
HOPPER 1	19.0m3	15.26T	13.3T	19.0T	13.3T
HOPPER 2	14.7m3	11.76T	10.29T	14.7T	10.29T
Optional Flush Tank 1600L					
TARE WEIGHT 8.4T					

Call our knowledgeable sales team today to discuss the TORNADO and which model will best suit your operations!



1800 27 1800 | sales@duraquip.com.au